

FREESPACE
FREESPACE

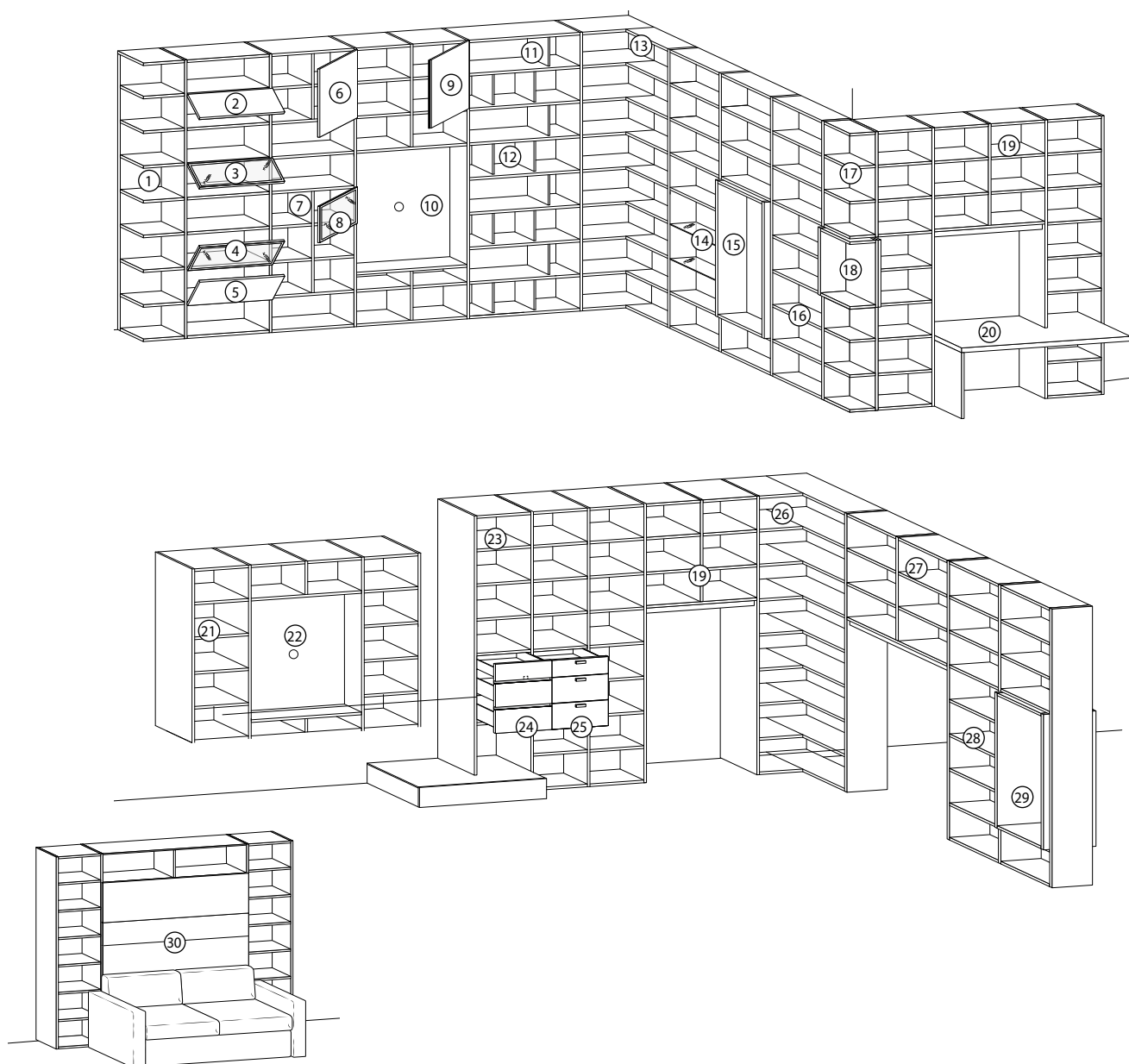

scheda tecnica data sheet



- | | |
|---|---|
| ① Terminale a terra Floor-standing end unit | ⑬ Modulo angolare monofacciale One-sided corner module |
| ② Anta vasistas Plana sp. 2.2 cm Plana lift-up door Th. 2.2 cm | ⑭ Ripiano in vetro trasparente temperato Transparent tempered glass shelf |
| ③ Anta vasistas City glass sp. 3.5 cm City glass lift-up door Th. 3.5 cm | ⑮ Nicchia monofacciale One-sided niche |
| ④ Anta ribalta City glass sp. 3.5 cm City glass flap door Th. 3.5 cm | ⑯ Modulo a terra Floor-standing module |
| ⑤ Anta ribalta Plana sp. 2.2 cm Plana flap door Th. 2.2 cm | ⑰ Angolo aperto Open corner |
| ⑥ Anta battente Plana sp. 2.2 cm Plana hinged door Th. 2.2 cm | ⑱ Nicchia ad angolo Corner niche |
| ⑦ Tramezza sp. 2.8 cm Partition th. 2.8 cm | ⑳ Ponte monofacciale One-sided overhead unit |
| ⑧ Anta battente City glass sp. 3.5 cm City glass hinged door Th. 3.5 cm | ㉑ Piano Scrittoio Desktop |
| ⑨ Anta battente Gola Gola hinged door | ㉒ Modulo sospeso Suspended module |
| ⑩ Modulo porta TV a terra Floor-standing TV module | ㉓ Modulo porta TV sospeso Suspended TV module |
| ⑪ Elemento divisorio sp. 1.8 cm Partition element th. 1.8 cm | ㉔ Modulo sovrapposto su contenitore Module on storage unit |
| ⑫ Elemento divisorio a C sp. 1.8 cm C-shaped partition element th. 1.8 cm | ㉕ Cassetti e cassettoni grip Grip drawers and deep drawers |
| ⑬ Modulo angolare monofacciale One-sided corner module | ㉖ Cassetti e cassettoni plana Plana drawers and deep drawers |
| ⑭ Ripiano in vetro trasparente temperato Transparent tempered glass shelf | ㉗ Angolo bifacciale 1 lato Double-sided corner |
| ⑮ Nicchia monofacciale One-sided niche | ㉘ Ponte bifacciale Double-sided overhead unit |
| ⑯ Modulo a terra Floor-standing module | ㉙ Modulo bifacciale Double-sided module |
| ⑰ Angolo aperto Open corner | ㉚ Nicchia bifacciale Double-sided niche |
| ⑱ Nicchia ad angolo Corner niche | ㉛ Modulo letto ribalta Module for fold-away bed |
| ⑳ Ponte monofacciale One-sided overhead unit | |
| ㉑ Piano Scrittoio Desktop | |
| ㉒ Modulo sospeso Suspended module | |
| ㉓ Modulo porta TV sospeso Suspended TV module | |
| ㉔ Modulo sovrapposto su contenitore Module on storage unit | |
| ㉕ Cassetti e cassettoni grip Grip drawers and deep drawers | |
| ㉖ Cassetti e cassettoni plana Plana drawers and deep drawers | |
| ㉗ Angolo bifacciale 1 lato Double-sided corner | |
| ㉘ Ponte bifacciale Double-sided overhead unit | |
| ㉙ Modulo bifacciale Double-sided module | |
| ㉚ Nicchia bifacciale Double-sided niche | |
| ㉛ Modulo letto ribalta Module for fold-away bed | |

ALTEZZE LIBRERIA A SPALLA | HEIGHTS OF BOOKCASE WITH SUPPORTING SIDE

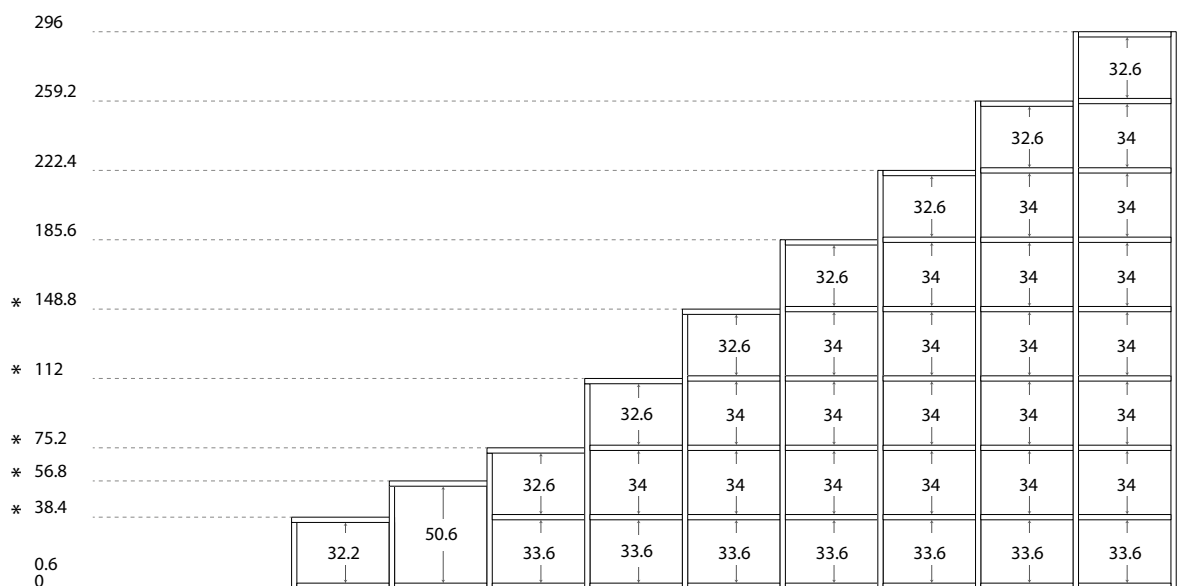

* Le colonne fino all'altezza 148.8 cm sono proposte con ripiano uso top
 Tall units up to the height 148.8 cm are with shelf used as top
 Altezze fianchi comprensiva di piedino h. 0.6 cm (regolabile fino a 2.5 cm)
 Heights of side panels with foot h. 0.6 cm (adjustable up to 2.5 cm)

LARGHEZZE LIBRERIA A SPALLA | WIDTHS OF BOOKCASE WITH SUPPORTING SIDE

Moduli con schiene a tutta altezza | Modules with full-height back panels



Moduli con schiene divise per ogni vano in altezza | Modules with back panels divided for each compartment in height.

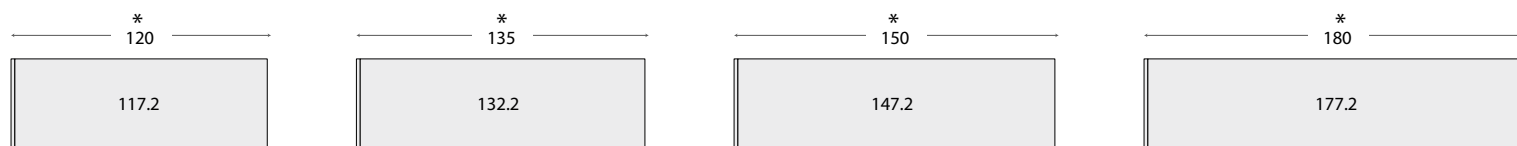

* Per le larghezze 120-135-150-180 è obbligatorio l'utilizzo di tramezze, elementi a C o elementi divisori.
 For widths of 120-135-150-180 inserts, C-shaped elements or partitions are obligatory.

PROFONDITÀ LIBRERIA A SPALLA | DEPTHS OF BOOKCASE WITH SUPPORTING SIDE

ANTA PLANA E GOLA | PLANA and GOLA DOORS



ANTA CITY GLASS | City Glass doors



ANGOLI MONOFACCIALI | ONE-SIDED CORNERS

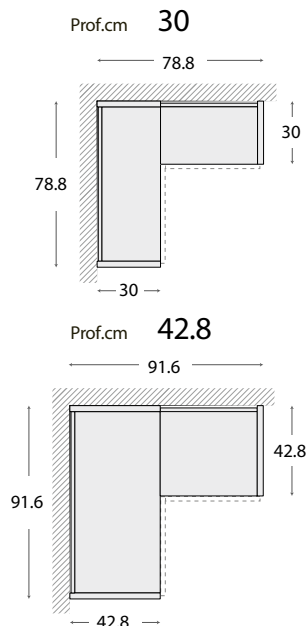

ANGOLI BIFACCIALI | DOUBLE-SIDED CORNERS

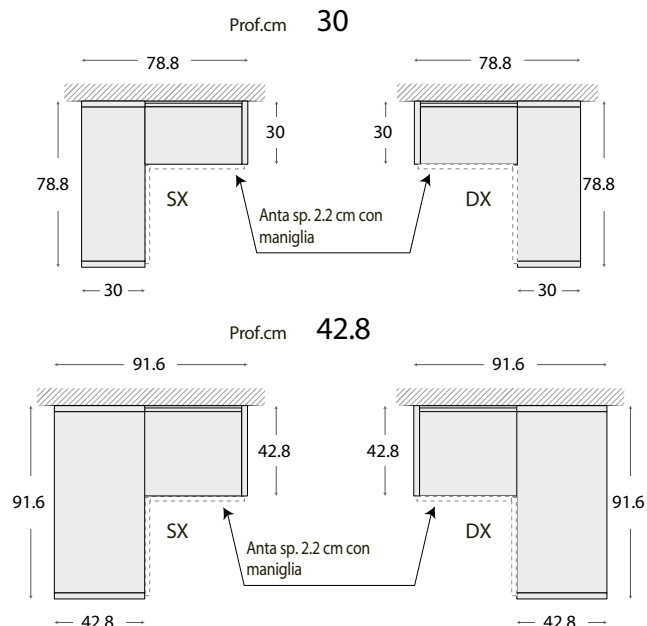

ANGOLI ESTERNI | EXTERNAL CORNERS

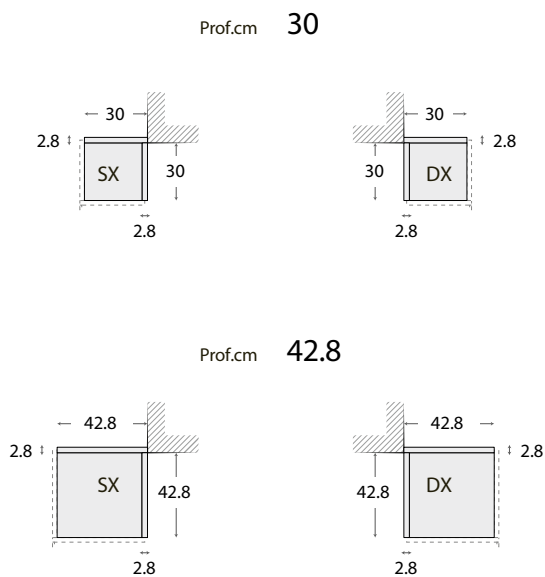

TERMINALI | END UNITS

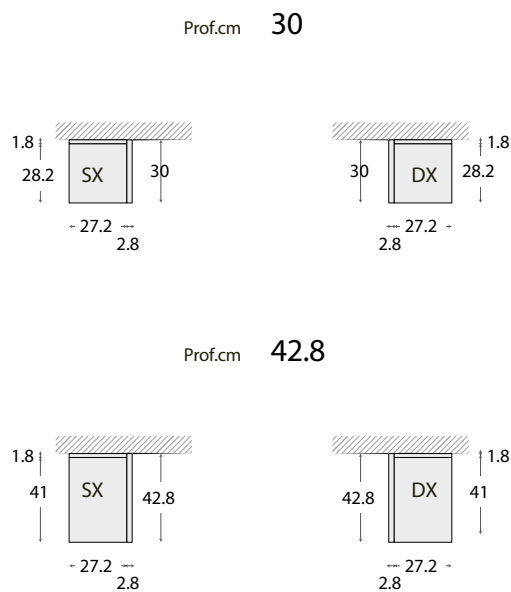

ESEMPIO DI COMBINAZIONI MODULARITÀ | EXAMPLE OF MODULAR COMBINATIONS

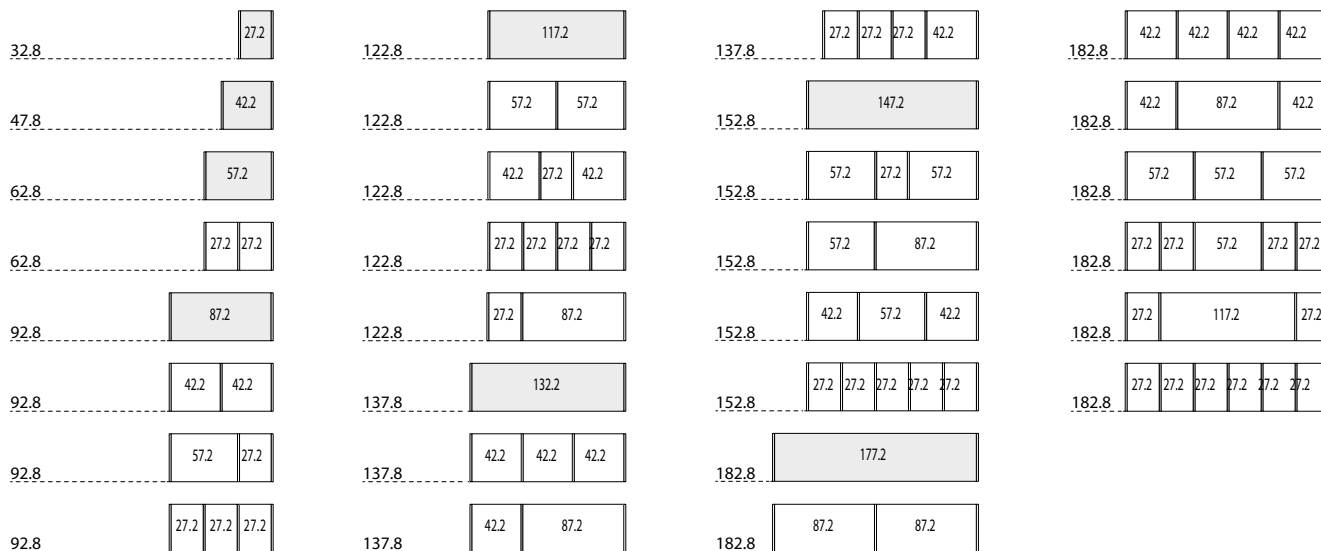

finitura liscia plain finish

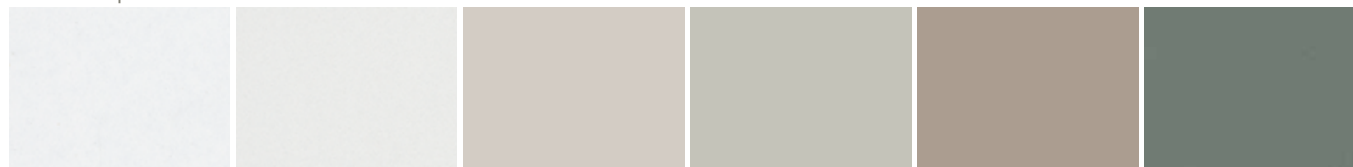

bianco talco
talc white

pomice
pumice

cashmere
cashmere

arena
arena

selce
flint

ottanio
octane



ardesia
slate

carbone
coal

mattone
brick

blu
blue

finitura materica textured finish

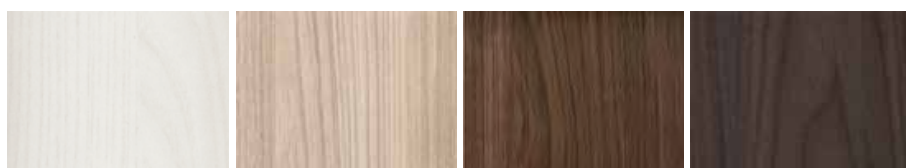

olmo ash
ash elm

olmo sand
sand elm

noce
walnut

lignum dark
lignum dark

solo per schiene librerie FREESPACE

only for FREESPACE bookcase back panels



cretto cashmere
cretto cashmere

cocò
cocò

ANTE A VETRO
GLASS DOORS

Ante City Glass

City Glass doors

vetro temprato tempered glass



trasparente
transparent

trasparente fumè
transparent smoked grey

riflettente chiaro
light reflective

Telai

Frames

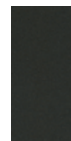

brunito
burnished

– La resa cromatica della stampa delle finiture e colori è da intendersi orientativa.
 Potrà essere non corrispondente al prodotto.

Avvalersi quindi delle mazzette colori in dotazione

– Norme e consigli per la manutenzione e pulizia dei prodotti:

Pulizia di superfici in melaminico e di vetri:

Utilizzare un panno morbido "eventualmente inumidito". Si raccomanda di non usare prodotti diluenti, solventi, abrasivi o corrosivi.

Non lasciare panni bagnati a contatto con le superfici in melaminico.

– Variazioni di tonalità di colore:

L'uniformità cromatica delle tinte unite e delle essenze può variare leggermente, ne consegue che in caso di completamenti una possibile differenza di tonalità non potrà costituire causa di contestazione.

– Colours and finishes are indicative as the printing process may alter them.

May not correspond to the product.

Use supplied colour range!

– Product maintenance and cleaning tips:

Cleaning of melamine surfaces and glasses:

Use a soft cloth, damp if necessary. Please do not use thinners, solvents, abrasive or corrosive substances.

Do not leave wet items in contact with melamine faced surfaces.

– Colours variations:

Shades of plain colours and wood species may vary slightly. In the event of completions, possible differences in shades cannot be cause for complaint.